

SCHMIDT 2 (H546)

PARTS CATALOG

First edition, September 2001

Ricoh Company, LTD.

SCHMIDT 2 (H546)

SCHMIDT 2 (H546)

PARTS CATALOG

This catalog gives the numbers and names of parts on this machine.

CONTENTS

1.EXTERIOR (H546).....	2
2.OPERATION PANEL (H546)	4
3.UPPER SCANNER UNIT (H546).....	6
4.LOWER SCANNER UNIT (H546).....	8
5.SCANNER DRIVE (H546)	10
6.LD UNIT (H546)	12
7.FUSING UNIT (H546)	14
8.PAPER TRANSFER (H546)	16
9.DRIVE SECTION (H546)	18
10.ELECTRICAL SECTION (H546).....	20
11.PAPER FEED UNIT (H546).....	22
12.PAPER FEED DRIVE (H546)	24
13.PAPER TRAY (H546)	26
PARTS INDEX	29

September ,20 ' 2001

1.EXTERIOR (H546)

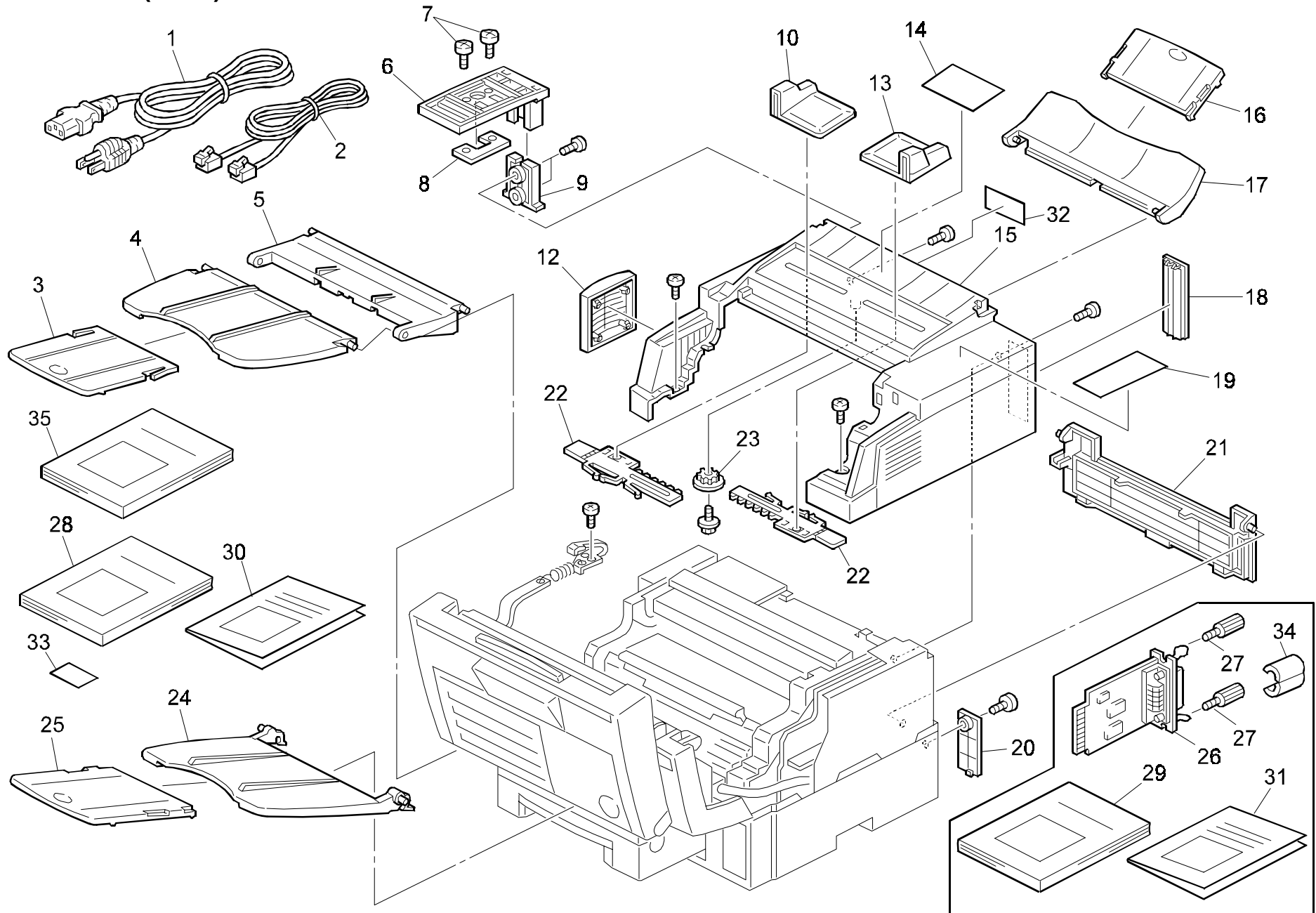

1.EXTERIOR (H546)

Index No.	Part No.	Description	Q'ty Per Assembly
1	1150 0024	Power Supply Cord - 230V (ASIA)	1
1	H545 5020	Power Supply Cord - 115V (US)	1
2	H523 5350	Telephone Cable (US/ASIA)	1
2	H545 5022	Telephone Cable (FRANCE)	1
3	H545 4315	Document Tray Extention (US/ASIA)	1
4	H545 4313	Document Tray	1
5	H545 4311	Document Table - 1	1
6	H545 4400	Handset Bracket	1
7	H081 4141	Screw - Handset	2
8	H505 4178	Stay - Hand Set	1
9	H545 4401	Handset Bracket Ass'y	1
10	H545 4303	Left Original Guide	1
12	H545 4330	Fan Cover	1
13	H545 4302	Right Original Guide	1
14	H545 1350	Decal - Original Position	1
15	H545 4300	Upper Cover	1
16	H545 4314	Document Table Extention (US/ASIA)	1
17	H545 4312	Document Table - 2	1
18	H545 4320	RS232C Interface Cover	1
19	H546 4385	Decal - Jampaper Removal-na	1
20	H545 4206	PC Interface Cover	1
21	H545 4224	Upper Rear Cover	1
22	H545 4307	Rack - Original Guide	2
23	H545 4308	Gear - Original Guide - 16Z	1
24	H545 2130	Copy Tray	1
25	H545 2131	Copy Tray Extention (US/AISA)	1
26	H545 6080	PC I/F Board	1
27	G012 1165	Knob Screw - M3X5	2
28	H546 8600	Basic Operation Manual (RIC NA)	1
28	H546 8609	Basic Operation Manual (ASIA)	1
28	H546 8629	Basic Operation Manual (NRG-ASIA)	1
28	H546 8630	Basic Operation Manual (SVN)	1
28	H546 8640	Basic Operation Manual (LAN)	1
29	H545 7214	Operation Manual - Win Styler (US)	1
29	H545 7216	Operation Manual - Win Styler (EUROPE)	1

Index No.	Part No.	Description	Q'ty Per Assembly
30	H546 8670	Installation Procedure:NA	1
30	H546 8679	Installation Manual - ASIA	1
31	H529 8710	Operation Manual - Bitware (US/ASIA)	1
32	H516 4153	Decal - Laser (EU/ASIA)	1
33	H545 3122	Decal F4 (ASIA)	1
34	H551 7258	Ferrite Core (US/ASIA)	1
35	H546 8641	Advanced Operation Manual (LAN)	1
35	H546 8700	Advanced Operation Manual (RIC NA)	1
35	H546 8701	Advanced Operation Manual (SVN)	1
35	H546 8702	Advanced Operation Manual (RIC ASIA)	1
35	H546 8703	Advanced Operation Manual (NRG ASIA)	1

2.OPERATION PANEL (H546)

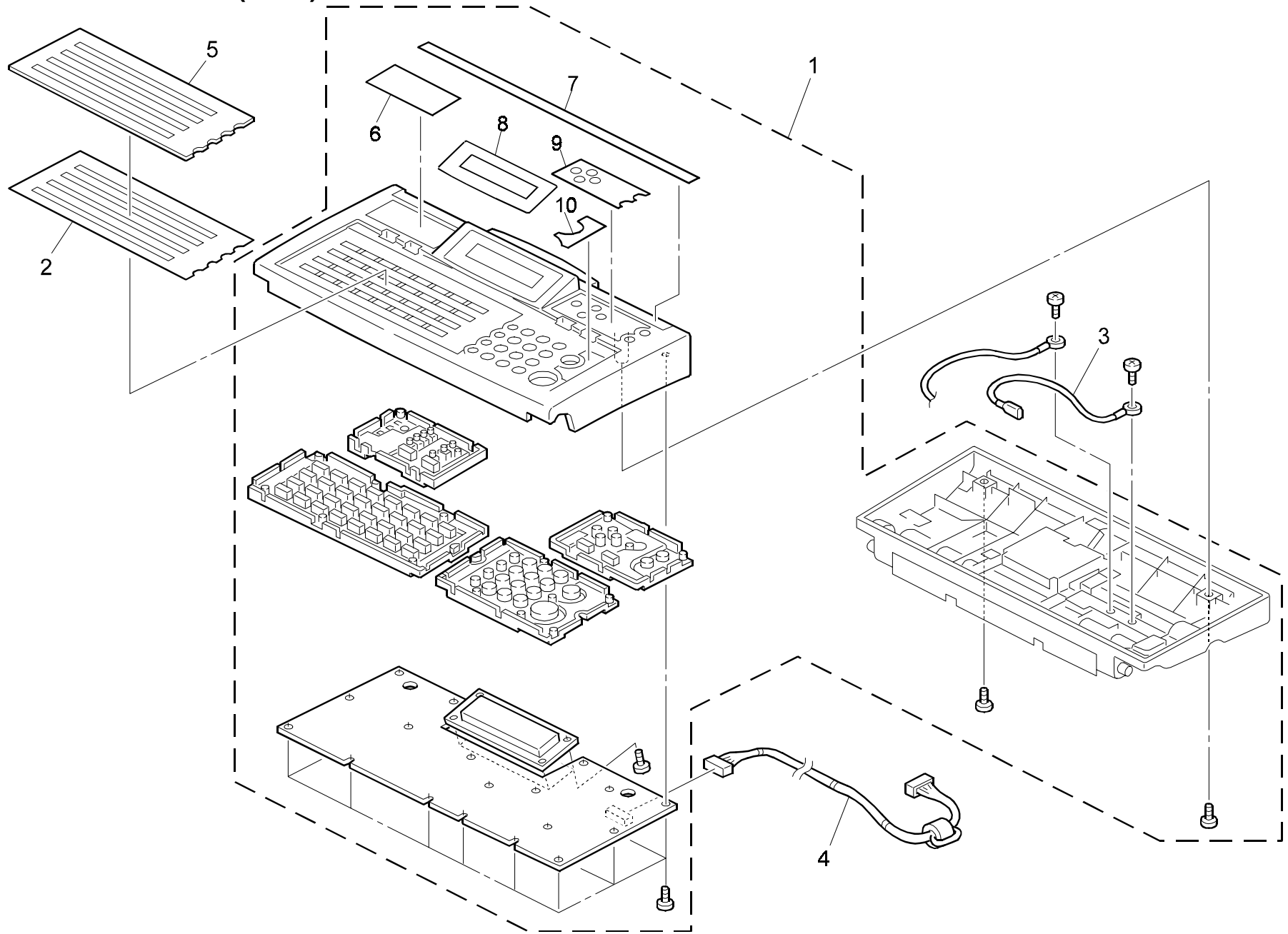

2.OPERATION PANEL (H546)

Index No.	Part No.	Description	Q'ty Per Assembly
1	H545 4609	Operation Panel Ass'y - EU NRG	1
1	H546 3600	Operation Panel Ass'y - US (RIC)	1
1	H546 3601	Operation Panel Ass'y (SVN)	1
1	H546 3602	Operation Panel Ass'y - EU-INFO	1
1	H546 3603	Operation Panel Ass'y - EUR (RIC)	1
1	H546 3604	Operation Panel Ass'y - ASIA (RIC)	1
1	H546 3605	Operation Panel Ass'y - ASIA-NRG	1
1	H546 3607	Operation Panel Ass'y - Lanier	1
2	H545 4655	Quick Dial Sheet	1
3	H545 5150	Grounding Wire - OPU	1
4	H545 5136	Harness:OPU	1
5	H545 4656	Quick Dial Cover	1
6	H545 4651	Decal- LED Left	1
7	H545 4654	Decal - Scale	1
8	H546 3620	Decal - LCD (RIC-US)	1
8	H546 3621	Decal - LCD (SVN)	1
8	H546 3622	Decal - LCD (INF)	1
8	H546 3623	Decal - LCD (RIC-EUR)	1
8	H546 3625	Decal - LCD (NRG)	1
8	H546 3628	Decal - LCD (LAN)	1
9	H545 4652	Decal - LED Right	1
10	H545 4653	Decal - Start/Stop	1

Index No.	Part No.	Description	Q'ty Per Assembly

3.UPPER SCANNER UNIT (H546)

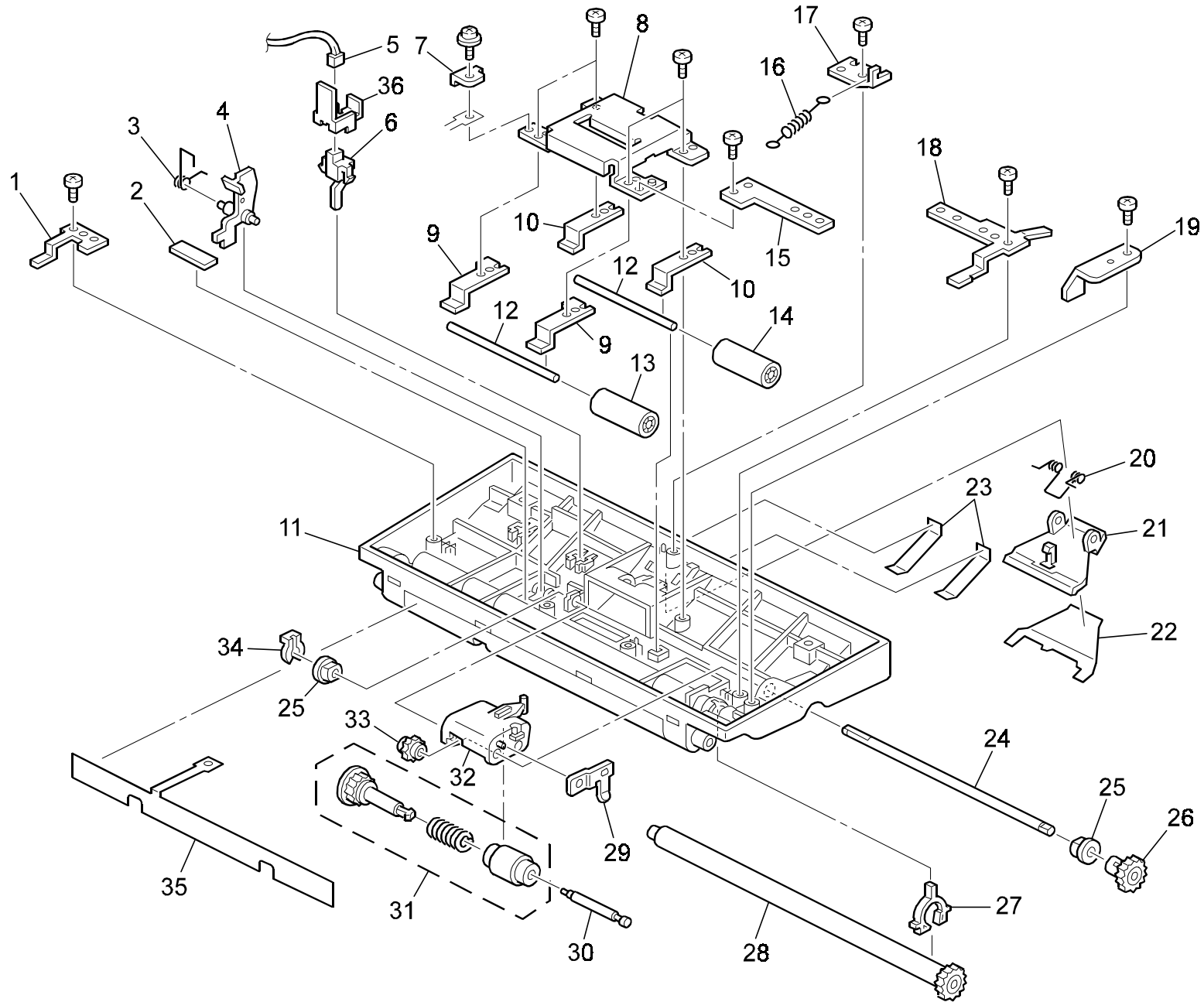

3.UPPER SCANNER UNIT (H546)

Index No.	Part No.	Description	Q'ty Per Assembly
1	H545 1124	Left Pressure Plate	1
2	H545 1538	Sheet - S2	1
3	H545 1127	Spring - S2	1
4	H545 1122	Actuator - S2	1
5	H545 5112	OPU-S1 Harness	1
6	H545 5054	Document Sensor - S1	1
7	H545 1537	Discharge Brush Holder	1
8	H545 1150	Support Plate	1
9	H545 1117	Pressure Roller R2	2
10	H545 1116	Pressure Roller R1	2
11	H545 1500	Upper Scanner Guide	1
12	H545 1105	Pressure Roller Shaft	2
13	H545 1136	Press Roller - R2	1
14	H545 1106	Pressure Roller	1
15	H545 1132	Upper Ground Plate	1
16	H545 1528	Separation Spring	1
17	H545 1536	Spring Anchor	1
18	H545 1123	Right Pressure Plate	1
19	H545 1535	Upper Guide Stopper	1
20	H545 1555	Spring - Pressure Plate	1
21	H545 1532	Pressure Plate - Pick-up	1
22	H545 1617	Pick-up Sheet	1
23	H545 1620	Pick-up Sheet 2	2
24	H545 1504	Reverse Position Shaft	1
25	H068 2102	Bushing - M6/M10 - 9	2
26	H545 1505	Gear - Separation - Right	1
27	H545 1118	Platen Roller Holder	1
28	H546 1050	Platen Roller	1
29	H545 1540	Reverse Pressure Plate	1
30	H545 1503	Reverse Roller Shaft	1
31	H545 1502	Separation Roller	1
32	H545 1501	Bracket - Separation Roller	1
33	H545 1506	Left Separation Gear - 24z	1
34	5447 2681	Snap Ring	1
35	H545 1126	Discharge Brush	1

Index No.	Part No.	Description	Q'ty Per Assembly
36	H545 1161	Stopper S1	1

4.LOWER SCANNER UNIT (H546)

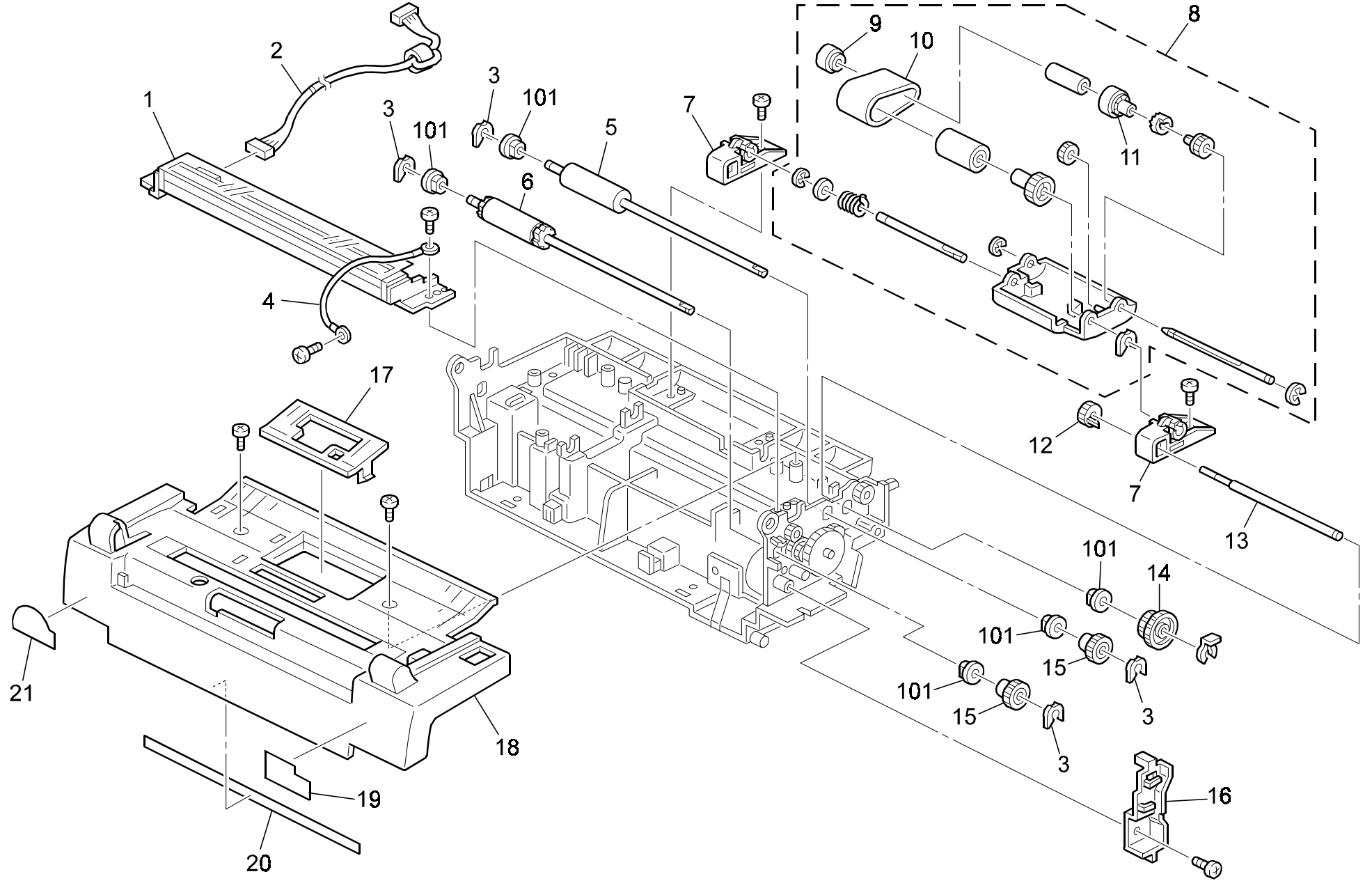

4.LOWER SCANNER UNIT (H546)

Index No.	Part No.	Description	Q'ty Per Assembly
1	H545 1030	Contact Image Sensor Ass'y	1
2	H545 5109	CIS Harness	1
3	H515 3543	E-ring - Jre4	5
4	H545 5152	Grounding Wire - Left Side	1
5	H545 1101	R1 Roller	1
6	H545 1102	R2 Roller	1
7	H545 1522	Feed Roller Holder	2
8	H545 1040	ADF Roller Unit	1
9	H545 1611	Left Pick-up Roller	1
10	H545 1550	Transfer Feed Belt	1
11	H545 1610	Right Pick-up Roller	1
12	H545 1509	ADF Gear - Left	1
13	H545 1607	Drive Shaft	1
14	H545 1508	ADF Gear - Right	1
15	H545 1113	Feed Roller Gear	2
16	H545 1160	Harness Guide	1
17	H545 1526	ADF Roller Cover	1
18	H545 1104	Scanner Cover	1
19	H553 3861	Decal:super G3	1
20	H545 2149	Discharge Brush	1
21	H516 4095	Decal - Energystar	1

Index No.	Part No.	Description	Q'ty Per Assembly
101	0805 3480	Bushing - 6mm	

5. SCANNER DRIVE (H546)

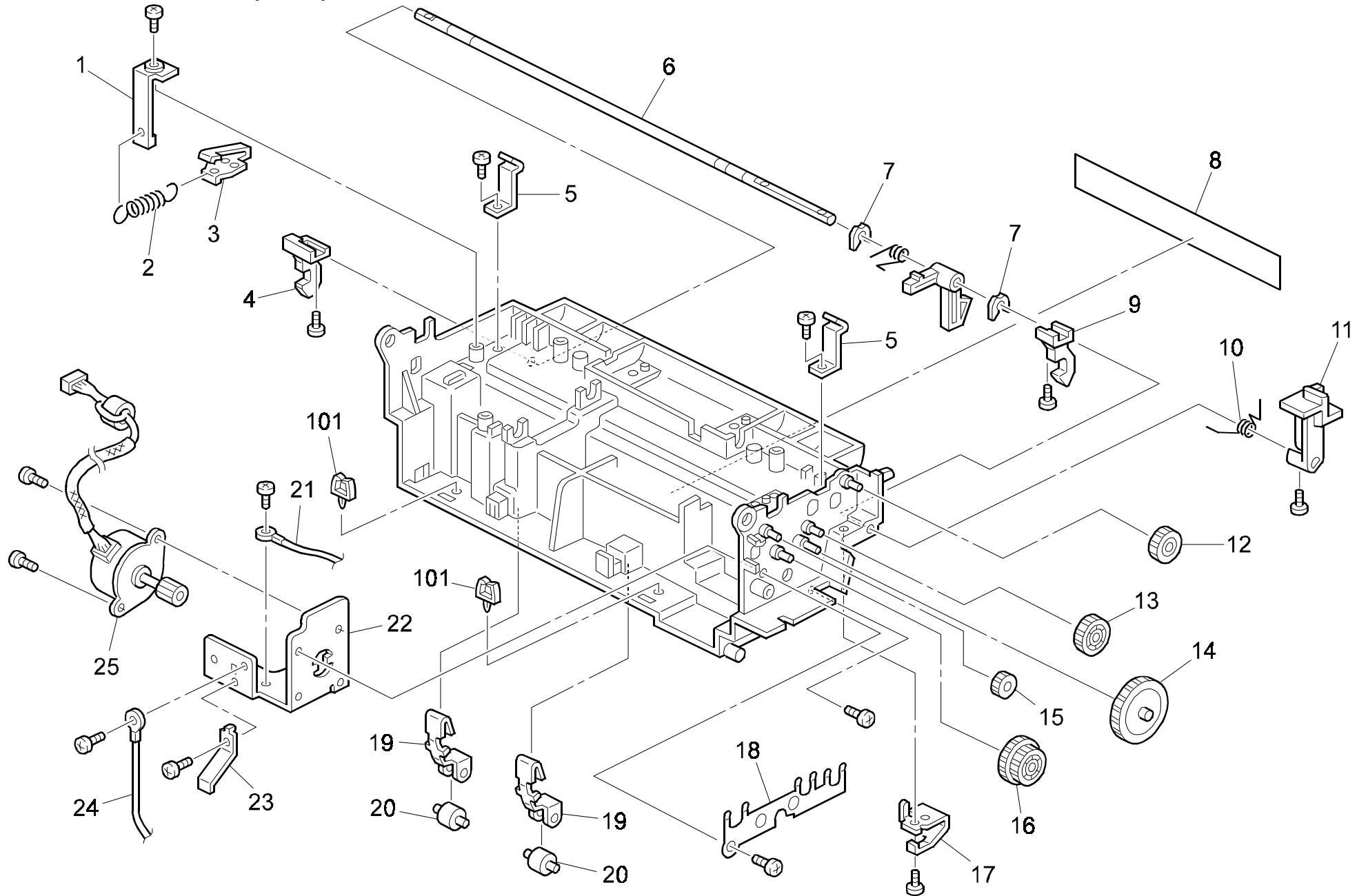

5. SCANNER DRIVE (H546)

Index No.	Part No.	Description	Q'ty Per Assembly
1	H545 4304	Scanner Stopper	1
2	H545 4327	Scanner Stopper Spring	1
3	H545 4306	Spring Plate	1
4	H545 4107	Left Release Plate	1
5	H545 1114	Lock Spring Plate	2
6	H545 4104	Scanner Release Shaft	1
7	H515 3543	E-ring - Jre4	2
8	H545 1191	Decal - High Temperature	1
9	H545 4106	Right Release Plate	1
10	H545 4108	Scanner Lock Spring	1
11	H545 4103	Scanner Release Lever	1
12	H545 1518	Idle Gear - Separation	1
13	H545 1111	Idle Gear - R1	1
14	H545 1110	Decelerator Gear	1
15	H545 1108	Idle Gear - Platen Rller	1
16	H545 1109	Idle Gear - R2	1
17	H545 4305	Spring Plate	1
18	H545 1125	Grounding Plate	1
19	H545 2132	Exit Roller Spring Plate	2
20	G012 4865	Exit Roller	2
21	H545 5151	Grounding Wire	1
22	H545 1107	Motor Bracket	1
23	H545 2154	Grounding Plate	1
24	H545 5152	Grounding Wire - Left Side	1
25	H545 1070	Scanner Motor	1
			

Index No.	Part No.	Description	Q'ty Per Assembly
101	1105 0229	Clamp	

6.LD UNIT (H546)

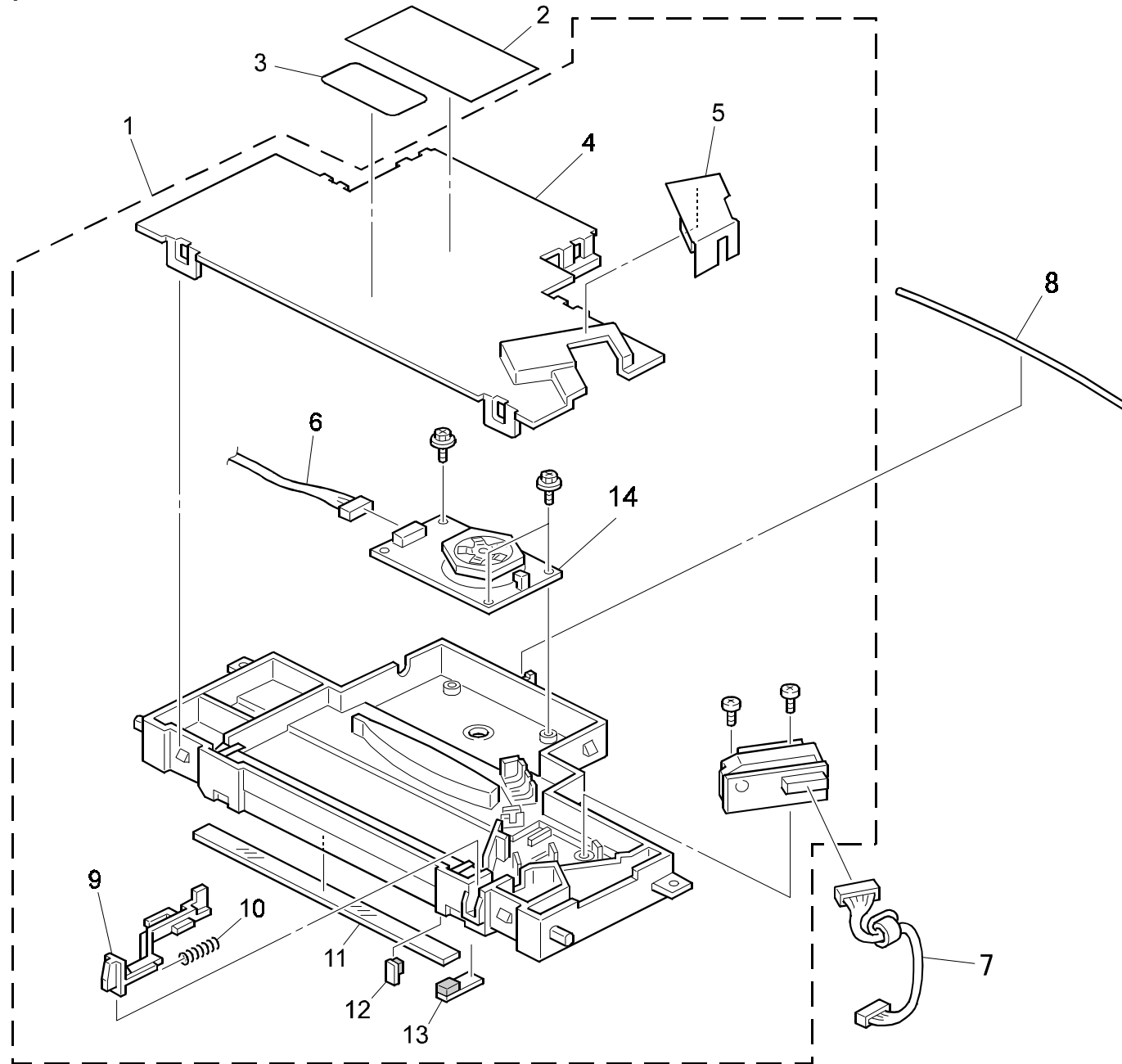

6.LD UNIT (H546)

Index No.	Part No.	Description	Q'ty Per Assembly
1	H545 2600	Laser Unit	1
2	H521 4056	Decal LD	1
3	H510 4170	Caution Label - Laser	1
4	H545 2602	Optical Housing Cover	1
5	H545 2640	Shield - laser Diode	1
6	H545 5106	Polygonal Motor Harness	1
7	H545 5107	Lddr Harness	1
8	H545 2428	Shaft Spring	1
9	H545 2606	Shield Plate	1
10	H545 2604	Pressure Spring	1
11	H545 2605	Shield Glass	1
12	H545 2642	Shield - Spring Plate	1
13	H545 2641	Shield - Shield Glass	1
14	H545 5068	Polygonal Mirror Motor - DC24V 0.3A	1

Index No.	Part No.	Description	Q'ty Per Assembly

7.FUSING UNIT (H546)

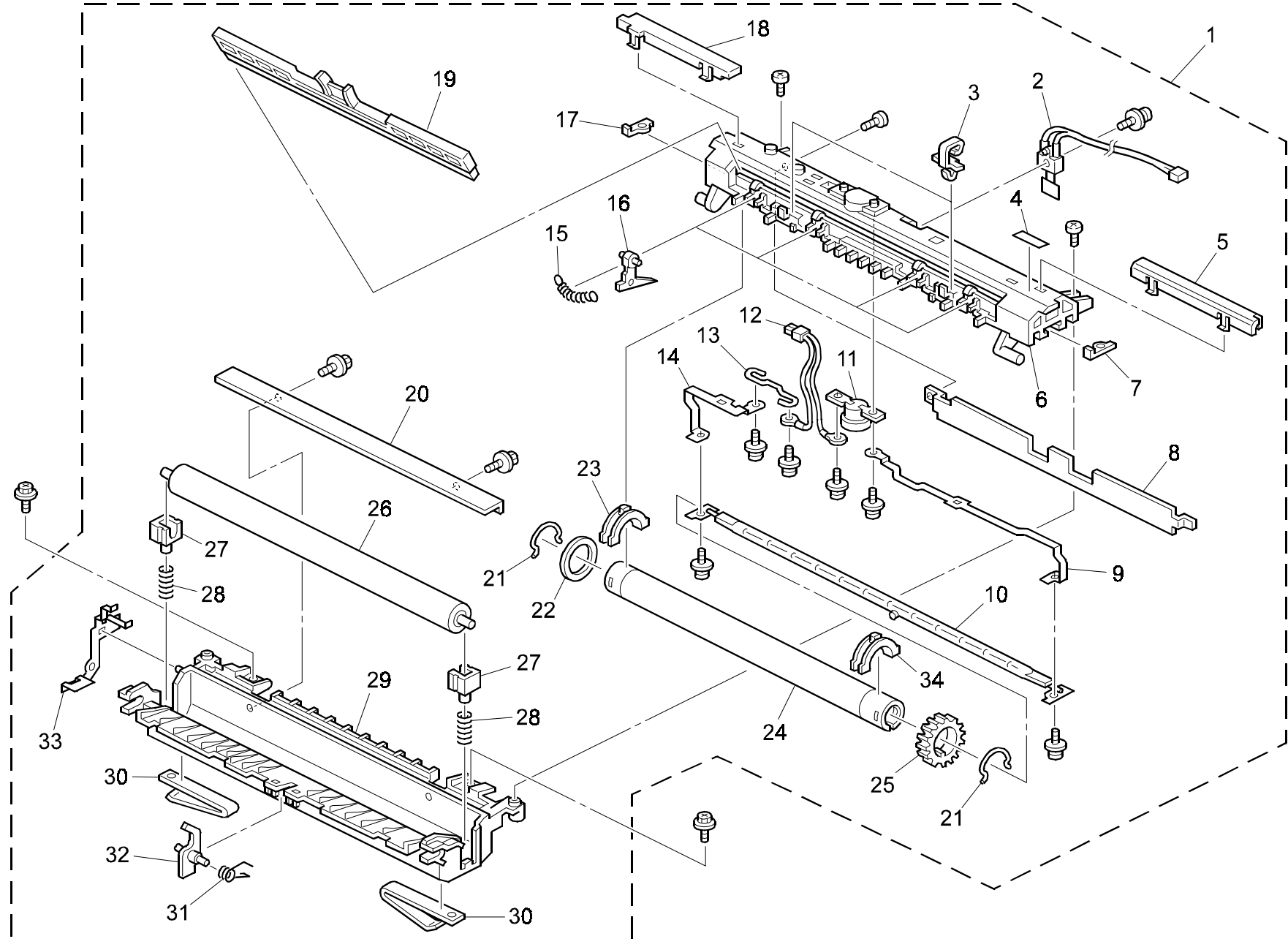

7.FUSING UNIT (H546)

Index No.	Part No.	Description	Q'ty Per Assembly
1	H545 2100	Fusing Unit - 115V	1
1	H545 2102	Fusing Unit - 230V (EUROPE)	1
1	H545 2103	Fusing Unit - 230V (ASIA)	1
2	H523 5020	Fusing Thermistor	1
3	H545 2148	Spring Plate - Cleaning	1
4	H545 2157	Decal - Warning (high Temperature)	1
5	H545 2144	Upper Right Cover	1
6	H545 2112	Upper Fusing Case	1
7	H545 2142	Plate - Fusing Lamp	1
8	H545 2156	Fusing Bracket	1
9	H545 2137	Right Terminal	1
10	H545 5059	Fusing Lamp - 115V	1
10	H545 5074	Fusing Lamp - 230V	1
11	H515 5017	Thermostat - Fusing	1
12	H545 5173	Fusing Lamp Harness	1
13	H516 5018	Thermofuse (EUROPE)	1
13	H545 5174	Jumper Harness (US/ASIA)	1
14	H545 2138	Left Terminal	1
15	H545 2129	Spring - Hot Roller Stripper	1
16	H545 2117	Hot Roller Stripper	1
17	H545 2141	Left Plate - Fusing Lamp	1
18	H545 2143	Upper Left Cover	1
19	H545 2109	Cleaning Pad	1
20	H545 2113	Entrance Guide Plate	1
21	H545 2119	Roller Stopper	2
22	H515 2141	Spacer - Hot Roller	1
23	H515 2137	Bearing - Hot Roller	1
24	H545 2110	Hot Roller	1
25	H545 2118	Hot Roller Gear	1
26	H545 2111	Pressure Roller	1
27	H545 2169	Bushing - Pressure Roller	2
28	H545 2122	Pressure Spring	2
29	H545 2126	Lower Fusing Case	1
30	H545 2158	Spring Plate - Fusing Pressure	2
31	H545 2146	Spring - Fusing Exit	1

Index No.	Part No.	Description	Q'ty Per Assembly
32	H545 2128	Paper Exit Feeler	1
33	H545 2147	Roller Grounding Plate	1
34	H515 2137	Bearing - hot Roller	1

8.PAPER TRANSFER (H546)

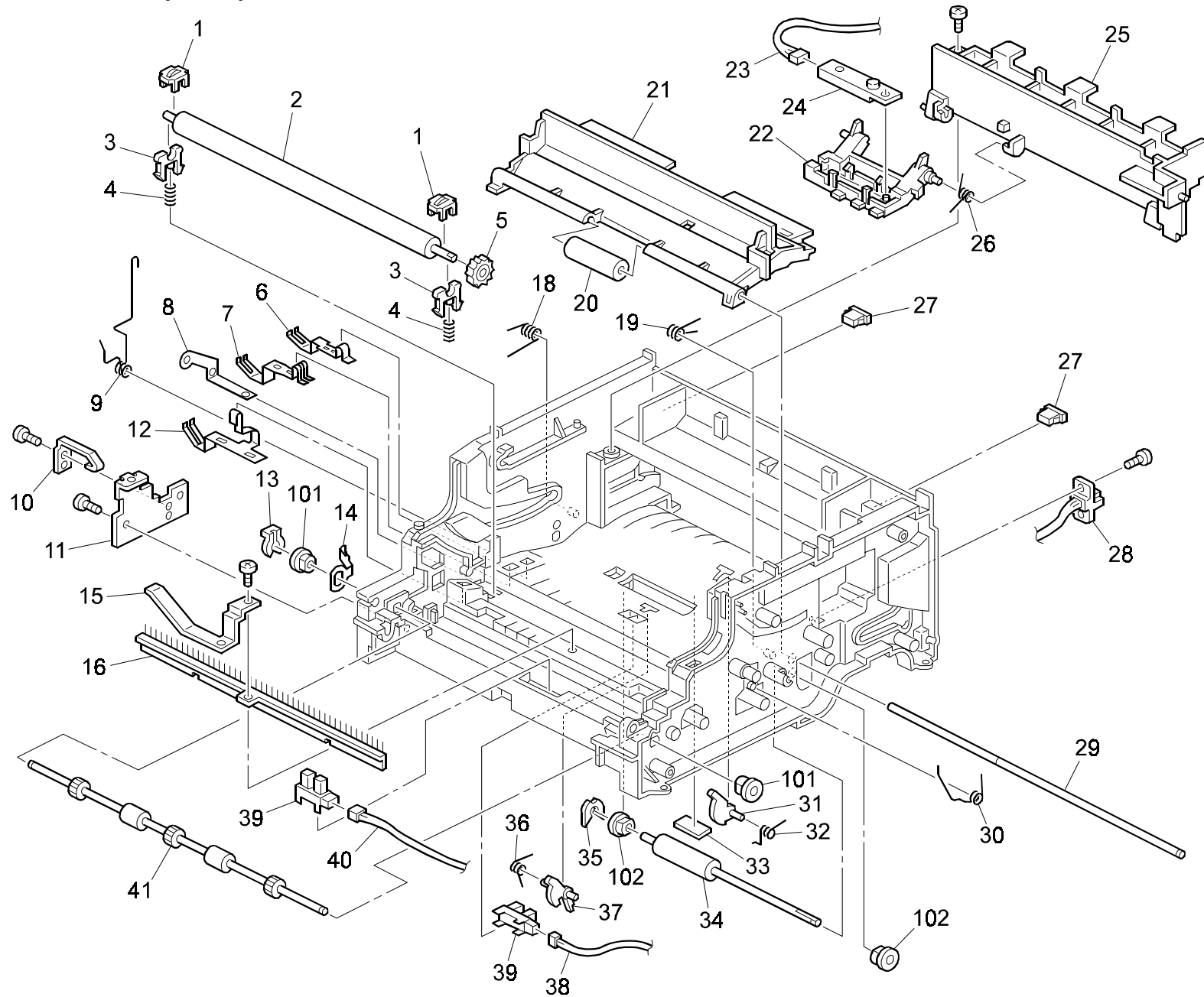

8.PAPER TRANSFER (H546)

Index No.	Part No.	Description	Q'ty Per Assembly
1	G025 3407	Bushing - Transfer Roller	2
2	G025 3410	Transfer Roller	1
3	G025 3403	Transfer Roller Bracket	2
4	G025 3404	Spring - Transfer Roller	2
5	G025 3405	Gear - 28Z	1
6	H545 2422	Terminal	1
7	H545 2421	Development Terminal	1
8	H545 2424	Transfer Terminal	1
9	H545 2420	Grounding Terminal	1
10	H545 2152	Grounding Plate - Fusing Unit	1
11	H545 4102	Left Bracket	1
12	H545 2423	Charge Terminal	1
13	5447 2681	Snap Ring	1
14	H545 2153	Grounding Plate - Exit Roller	1
15	H545 2432	Grounding Plate	1
16	H545 2431	Discharge Brush - Transfer Roller	1
18	H545 2401	Spring - Feed Roller - Left	1
19	H545 2402	Spring - Feed Roller - Right	1
20	H545 2404	Tension Roller	1
21	H545 3152	Upper Paper Guide	1
22	H545 2418	Tonner End Sensor Holder	1
23	H545 5102	Harness - Toner End Sensor	1
24	H545 5078	Toner End Sensor	1
25	H545 2417	Motor Cover	1
26	H545 2419	Spring - Tonner End Sensor	1
27	AA02 1030	Magnet Catch	2
28	H545 5116	Main Harness - Multch Purpose	1
29	H545 2403	Tension Roller Shaft	1
30	H545 2430	Lock Spring	1
31	H545 3119	Actuator - Paper End	1
32	H545 3123	Spring - Paper End Sensor	1
33	H545 3196	Sheet - PES	1
34	H545 2405	Feed Roller	1
35	H515 3543	E-ring - Jre4	1
36	H545 2426	Spring - Registration Sensor	1

Index No.	Part No.	Description	Q'ty Per Assembly
37	H545 2425	Actuator - Registration Sensor	1
38	H545 5101	Resist Harness	1
39	H523 5003	Photointerruptor	2
40	H545 5105	Exit Sensor Harness	1
41	H545 2124	Exit Roller	1
101	0805 3366	Bushing - 6mm	
102	0805 3480	Bushing - 6mm	

9.DRIVE SECTION (H546)

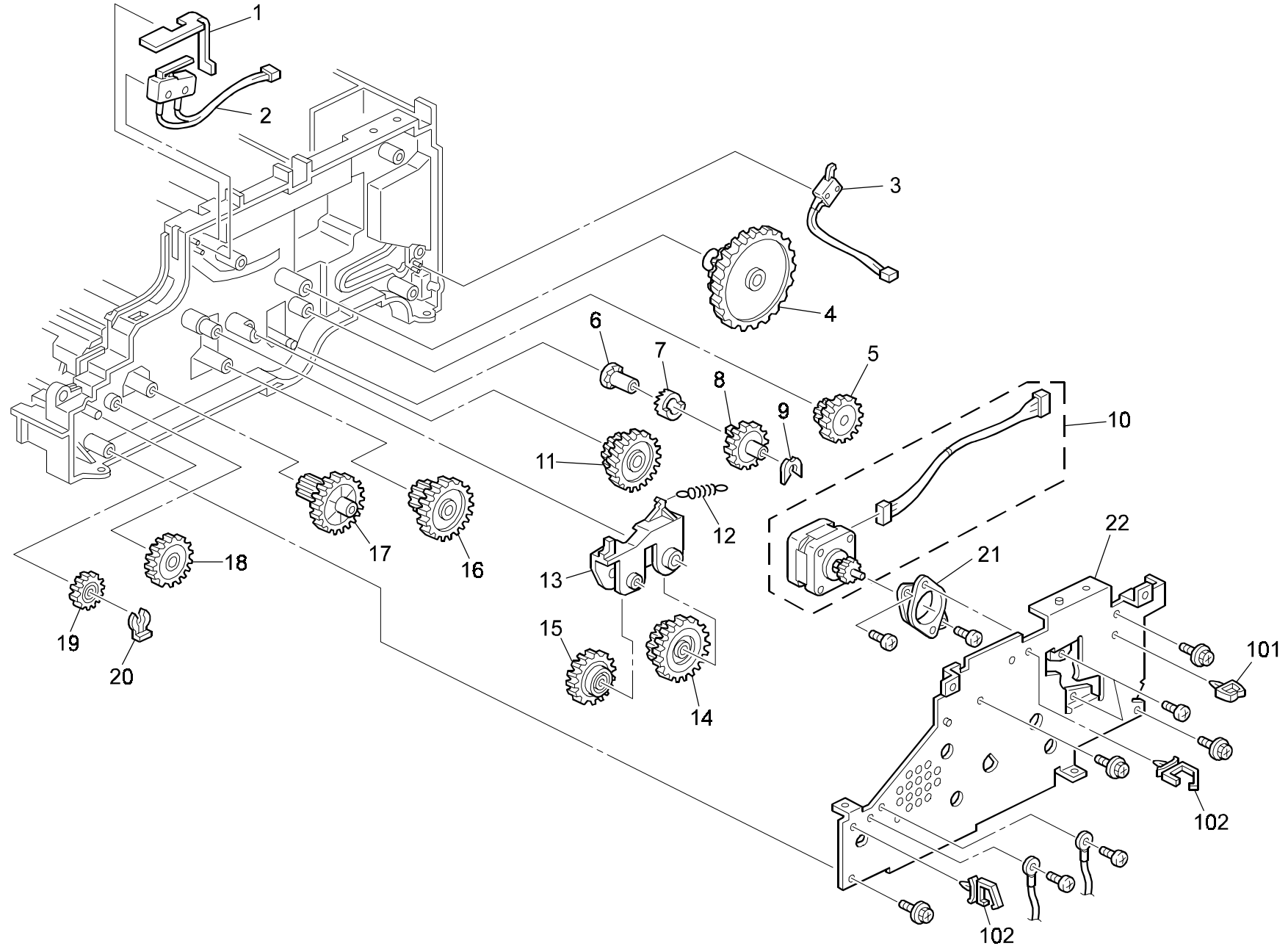

9.DRIVE SECTION (H546)

Index No.	Part No.	Description	Q'ty Per Assembly
1	H545 2427	Spring Plate	1
2	H545 5067	Interlock SW - 5V	1
3	H545 5060	Lever Switch Ass'y	1
4	H545 2411	Coupled Gear - 105/32z	1
5	H545 2409	Coupled Gear 33/19z	1
6	H545 2408	Feed Roller Color - Drive	1
7	H545 2407	Feed Roller Color	1
8	H545 2406	Gear - Feed Roller - 43Z	1
9	H515 3543	E-ring - Jre4	1
10	H545 5066	Main Motor - DC 20W	1
11	H545 2412	Coupled Gear - 41/23z	1
12	H545 2410	Release Spring	1
13	H545 2416	Gear Link Arm	1
14	H545 2414	Coupled Gear - 41/40z	1
15	H545 2415	Gear - 43Z	1
16	H545 2413	Coupled Gear - 54/23z	1
17	H545 2150	Fusing Drive Gear - 18z	1
18	H545 2151	Gear - 46Z	1
19	H545 2133	Gear Paper Exit Roller - 21Z	1
20	H515 3543	E-ring - Jre4	1
21	H545 2429	Stepping Motor Dumper	1
22	H545 4101	Right Side Plate	1

Index No.	Part No.	Description	Q'ty Per Assembly
101	1105 0234	Clamp	1
102	1105 0460	Clamp	1

10.ELECTRICAL SECTION (H546)

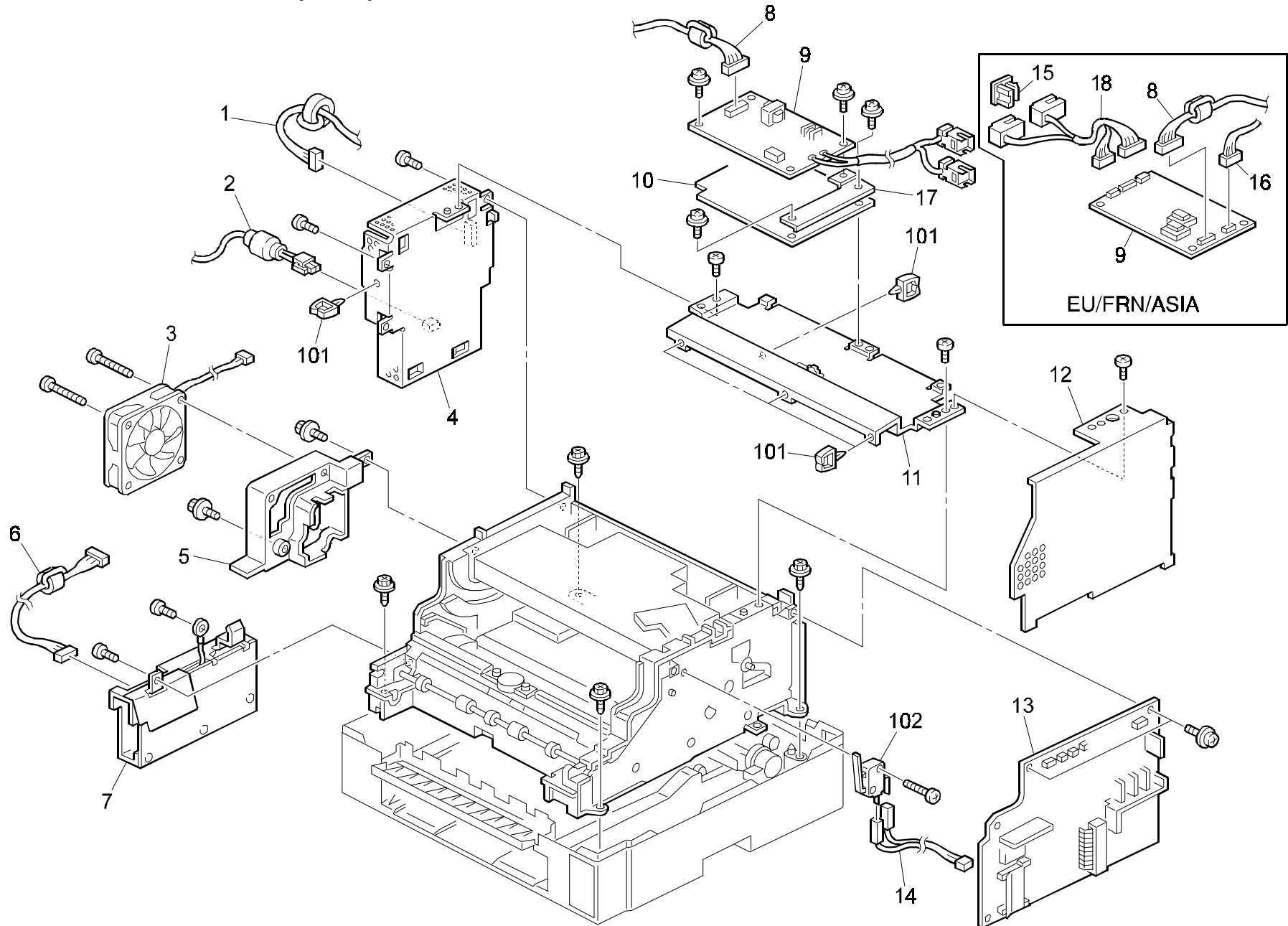

10.ELECTRICAL SECTION (H546)

Index No.	Part No.	Description	Q'ty Per Assembly
1	H545 5114	PSU Harness	1
2	H545 5135	Harness PSU-Heater	1
3	H545 5065	Fan Motor	1
4	H545 5000	PCB - PSU - 115V	1
4	H545 5001	PCB - PSU - 230V	1
5	H545 4120	Fan Motor Duct	1
6	H545 5110	Harness PP (US/ASIA)	1
6	H545 5134	Harness PP (EUROPE)	1
7	H545 5010	Power Pack	1
8	H545 5104	NCU 1 Harness (US)	1
8	H545 5125	NCU 2 Harness (EUROPE/ASIA)	1
9	5488 6156	PCB - NCU - Fax S2	1
9	H545 5930	PCB-NCU (US)	1
10	H545 4111	Shielding Sheet - NCU	1
11	H545 4105	NCU Stay	1
12	H545 4109	Shielding Plate - FCU	1
13	H546 6120	FCU Board - NA	1
13	H546 6135	FCU Board Ass'y - EU2	1
14	H545 5119	Safety Switch Harness	1
15	H504 4901	Cap - Telephone Socket	1
16	H545 5126	Harness - NCU3 (EUROPE/ASIA)	1
17	H546 3301	NCU Bracket	1
18	H546 5101	Harness Modular Connector EU2	1

Index No.	Part No.	Description	Q'ty Per Assembly
101	1105 0234	Clamp	
102	1204 2355	Micro Switch - AM51632A531	

11.PAPER FEED UNIT (H546)

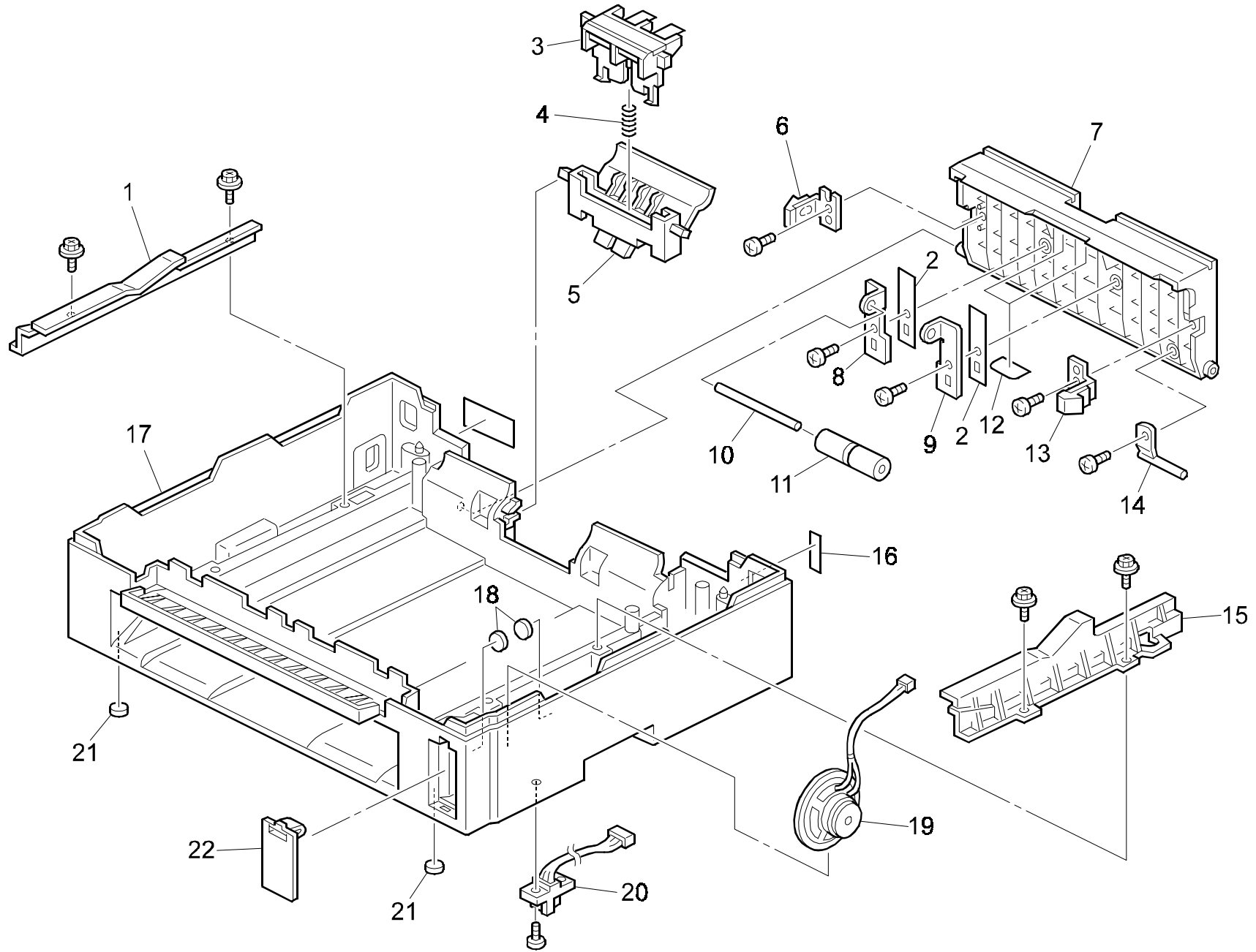

11.PAPER FEED UNIT (H546)

Index No.	Part No.	Description	Q'ty Per Assembly
1	H545 3191	Left Guide Rail	1
2	H545 3200	Spring Plate	2
3	H545 3155	Separation Pad:ass'y	1
4	G800 3147	Pressure Spring - 2.8n	1
5	H545 3157	Separation Pad Cover	1
6	H545 4222	Lock Spring Plate	1
7	H545 4201	Lower Rear Cover	1
8	H545 3195	Pressure Plate - Left	1
9	H545 3194	Pressure Plate - Right	1
10	H545 3148	Roller Shaft	1
11	H545 3143	Transfer Drive Roller	1
12	H545 4223	Film - Reverse	2
13	H545 4222	Lock Spring Plate	1
14	H545 4211	Cover Shaft	1
15	H545 3190	Right Guide Rail	1
16	H545 4213	Decal - Parallel	1
17	H545 4200	Lower Cover	1
18	5214 1221	Rubber Foot	2
19	H545 5064	Speaker	1
20	H545 5137	Main Harness - 2nd	1
21	5214 1221	Rubber Foot	2
22	H545 4205	Memory Card Cover	1

Index No.	Part No.	Description	Q'ty Per Assembly

12.PAPER FEED DRIVE (H546)

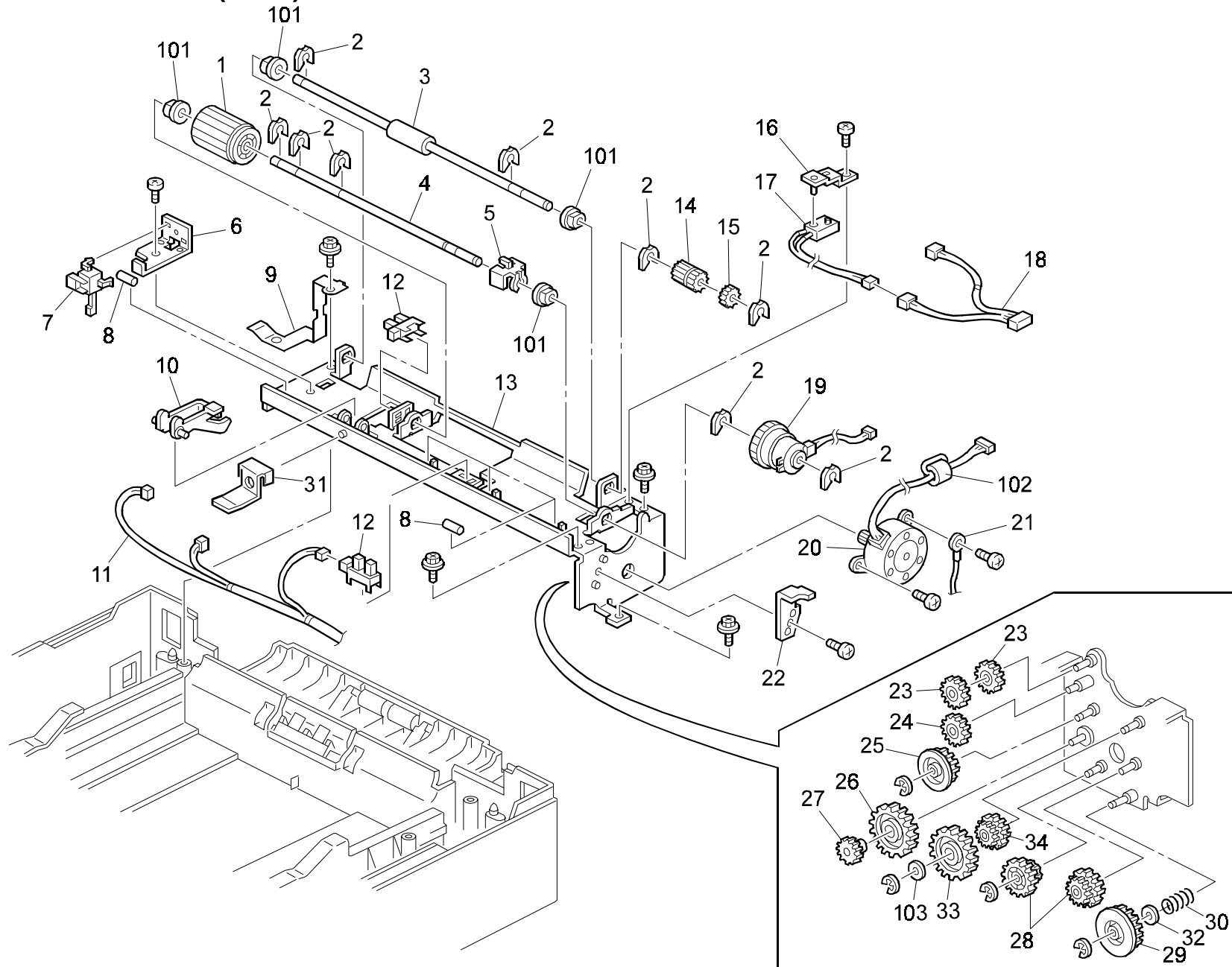

12.PAPER FEED DRIVE (H546)

Index No.	Part No.	Description	Q'ty Per Assembly
1	H545 3125	Paper Feed Roller	1
2	H515 3543	E-ring - Jre4	9
3	H545 3141	Paper Transfer Roller	1
4	H545 3144	Feed Roller Shaft	1
5	H545 3127	Shaft Stopper	1
6	H545 3180	Position Sensor Bracket	1
7	H545 5076	Paper Transfer Sensor	1
8	H001 4221	Harness Clamper	2
9	H545 4121	Grounding Plate - PSU	1
10	H545 3132	Actuator - Paper Cassette	1
11	H545 5133	Paper Feed Sensor Harness	1
12	H523 5003	Photointerrupter	2
13	H535 3160	Paper Feed Bracket	1
14	H545 3176	Idler Gear 4 - 14z	1
15	H545 3177	Gear 4 - 14Z	1
16	H545 3160	Micro Switch Holder	1
17	H545 5061	Rear Cover Sensor Ass'y	1
18	H545 5103	Harness - Cover Open Sensor	1
19	H546 5070	Magnetic Clutch - MIC2.5NE:5W	1
20	H535 5063	Paper Feed Motor	1
21	H545 5151	Grounding Wire	1
22	H545 3189	Magnetic Clutch Bracket	1
23	H545 3175	Idler Gear 3 - 15z	1
24	H545 3174	Idler Gear 2 - 14z	1
25	H545 3173	Idler Gear 1 - 23z	1
26	H545 3171	Gear 2 - 31Z	1
27	H545 3172	Gear 3 - 16Z	1
28	H545 3170	Gear 1 - 14Z	2
29	H545 3130	Idle Gear - 2nd - 24z	1
30	H545 3178	Spring - Gear	1
31	H545 2433	Ground Plate - Feed Roller -Plotter	1
32	H545 3179	Spacer	1
33	H545 3199	Slow Down Gear - Lite	1
34	H535 3185	Gear - 15Z	1

Index No.	Part No.	Description	Q'ty Per Assembly
101	0805 3480	Bushing - 6mm	
102	1607 1046	Ferrite Core TC-15-10-12-FC	
103	0807 2022	Washer - 3.3x10x0.5mm	

13.PAPER TRAY (H546)

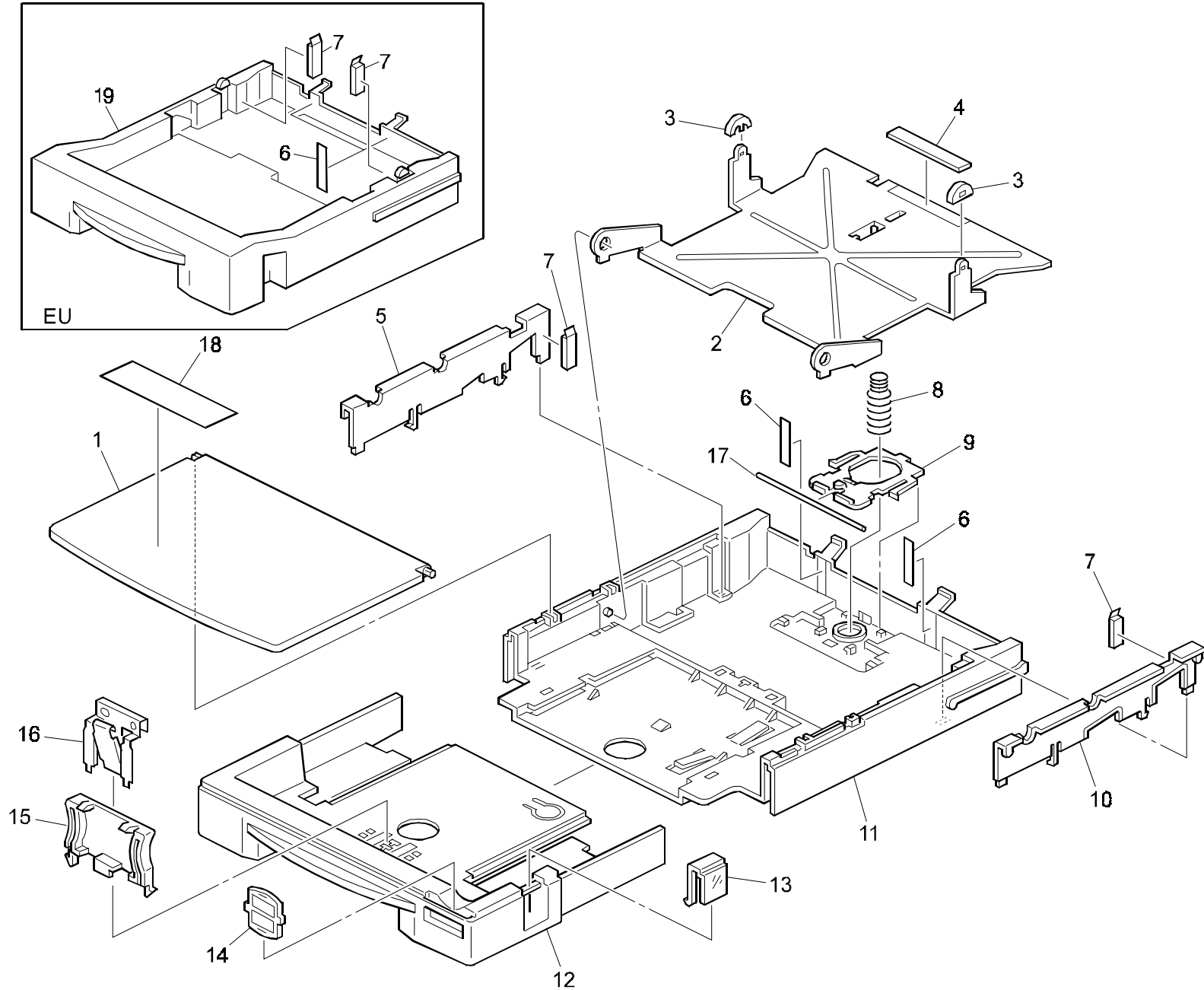

13.PAPER TRAY (H546)

Index No.	Part No.	Description	Q'ty Per Assembly
1	H545 3103	Cassette Cover (US/ASIA)	1
2	H545 3102	Bottom Plate	1
3	H545 3111	Bottom Plate Cap	2
4	H545 3115	Bottom Plate Pad	1
5	H545 3105	Left Side Fence Ass'y (US/ASIA)	1
6	H545 3192	Cassette Film	2
7	H545 3114	Side Fence Sheet	2
8	H545 3110	Spring	1
9	H545 3109	Bottom Plate Lever	1
10	H545 3104	Right Side Fence Ass'y (US/ASIA)	1
11	H545 3100	Cassette Ass'y (US/ASIA)	1
12	H545 3101	Cassette Slider (US/ASIA)	1
13	H545 3112	Paper Level Plate (US/ASIA)	1
14	H545 3107	Paper Size Selector (US/ASIA)	1
15	H545 3106	End Fence	1
16	H545 3113	End Fence Spring	1
17	H545 3116	Lever Spring	1
18	H545 4362	Decal - Cassette Cover	1
19	H535 3010	Cassette Ass'y (EUROPE)	1

Index No.	Part No.	Description	Q'ty Per Assembly

Parts Index

Parts Index

Part No.	Description	Page and Index No.
H546 1050	Platen Roller	7- 28
H546 3301	NCU Bracket	21- 17
H546 3600	Operation Panel Ass'y - US (RIC)	5- 1
H546 3601	Operation Panel Ass'y (SVN)	5- 1
H546 3602	Operation Panel Ass'y - EU-INFO	5- 1
H546 3603	Operation Panel Ass'y - EUR (RIC)	5- 1
H546 3604	Operation Panel Ass'y - ASIA (RIC)	5- 1
H546 3605	Operation Panel Ass'y - ASIA-NRG	5- 1
H546 3607	Operation Panel Ass'y - Lanier	5- 1
H546 3620	Decal - LCD (RIC-US)	5- 8
H546 3621	Decal - LCD (SVN)	5- 8
H546 3622	Decal - LCD (INF)	5- 8
H546 3623	Decal - LCD (RIC-EUR)	5- 8
H546 3625	Decal - LCD (NRG)	5- 8
H546 3628	Decal - LCD (LAN)	5- 8
H546 4385	Decal - Jampaper Removal-na	3- 19
H546 5070	Magnetic Clutch - MIC2.5NE:5W	25- 19
H546 5101	Harness Modular Connector EU2	21- 18
H546 6120	FCU Board - NA	21- 13
H546 6135	FCU Board Ass'y - EU2	21- 13
H546 8600	Basic Operation Manual (RIC NA)	3- 28
H546 8609	Basic Operation Manual (ASIA)	3- 28
H546 8629	Basic Operation Manual (NRG-ASIA)	3- 28
H546 8630	Basic Operation Manual (SVN)	3- 28
H546 8640	Basic Operation Manual (LAN)	3- 28
H546 8641	Advanced Operation Manual (LAN)	3- 35
H546 8670	Installation Procedure:NA	3- 30
H546 8679	Installation Manual - ASIA	3- 30
H546 8700	Advanced Operation Manual (RIC NA)	3- 35
H546 8701	Advanced Operation Manual (SVN)	3- 35
H546 8702	Advanced Operation Manual (RIC ASIA)	3- 35
H546 8703	Advanced Operation Manual (NRG ASIA)	3- 35

Part No.	Description	Page and Index No.
G012 1165	Knob Screw - M3X5	3- 27
G012 4865	Exit Roller	11- 20
G025 3403	Transfer Roller Bracket	17- 3
G025 3404	Spring - Transfer Roller	17- 4
G025 3405	Gear - 28Z	17- 5
G025 3407	Bushing - Transfer Roller	17- 1
G025 3410	Transfer Roller	17- 2
G800 3147	Pressure Spring - 2.8n	23- 4
H001 4221	Harness Clamper	25- 8
H068 2102	Bushing - M6/M10 - 9	7- 25
H081 4141	Screw - Handset	3- 7
H504 4901	Cap - Telephone Socket	21- 15
H505 4178	Stay - Hand Set	3- 8
H510 4170	Caution Label - Laser	13- 3
H515 2137	Bearing - Hot Roller	15- 23
H515 2137	Bearing - hot Roller	15- 34
H515 2141	Spacer - Hot Roller	15- 22
H515 3543	E-ring - Jre4	11- 7
H515 3543	E-ring - Jre4	19- 9
H515 3543	E-ring - Jre4	9- 3
H515 3543	E-ring - Jre4	25- 2
H515 3543	E-ring - Jre4	19- 20
H515 3543	E-ring - Jre4	17- 35
H515 5017	Thermostat - Fusing	15- 11
H516 4095	Decal - Energystar	9- 21
H516 4153	Decal - Laser (EU/ASIA)	3- 32
H516 5018	Thermofuse (EUROPE)	15- 13
H521 4056	Decal LD	13- 2
H523 5003	Photointerrupter	25- 12
H523 5003	Photointerrupter	17- 39
H523 5020	Fusing Thermistor	15- 2
H523 5350	Telephone Cable (US/ASIA)	3- 2
H529 8710	Operation Manual - Bitware (US/ASIA)	3- 31
H535 3010	Cassette Ass'y (EUROPE)	27- 19
H535 3160	Paper Feed Bracket	25- 13

Part No.	Description	Page and Index No.
H535 3185	Gear - 15Z	25- 34
H535 5063	Paper Feed Motor	25- 20
H545 1030	Contact Image Sensor Ass'y	9- 1
H545 1040	ADF Roller Unit	9- 8
H545 1070	Scanner Motor	11- 25
H545 1101	R1 Roller	9- 5
H545 1102	R2 Roller	9- 6
H545 1104	Scanner Cover	9- 18
H545 1105	Pressure Roller Shaft	7- 12
H545 1106	Pressure Roller	7- 14
H545 1107	Motor Bracket	11- 22
H545 1108	Idle Gear - Platen Rller	11- 15
H545 1109	Idle Gear - R2	11- 16
H545 1110	Decelerator Gear	11- 14
H545 1111	Idle Gear - R1	11- 13
H545 1113	Feed Roller Gear	9- 15
H545 1114	Lock Spring Plate	11- 5
H545 1116	Pressure Roller R1	7- 10
H545 1117	Pressure Roller R2	7- 9
H545 1118	Platen Roller Holder	7- 27
H545 1122	Actuator - S2	7- 4
H545 1123	Right Pressure Plate	7- 18
H545 1124	Left Pressure Plate	7- 1
H545 1125	Grounding Plate	11- 18
H545 1126	Discharge Brush	7- 35
H545 1127	Spring - S2	7- 3
H545 1132	Upper Ground Plate	7- 15
H545 1136	Press Roller - R2	7- 13
H545 1150	Support Plate	7- 8
H545 1160	Harness Guide	9- 16
H545 1161	Stopper S1	7- 36
H545 1191	Decal - High Temperature	11- 8
H545 1350	Decal - Original Position	3- 14
H545 1500	Upper Scanner Guide	7- 11
H545 1501	Bracket - Separation Roller	7- 32

Part No.	Description	Page and Index No.
H545 1502	Separation Roller	7- 31
H545 1503	Reverse Roller Shaft	7- 30
H545 1504	Reverse Position Shaft	7- 24
H545 1505	Gear - Separation - Right	7- 26
H545 1506	Left Separation Gear - 24z	7- 33
H545 1508	ADF Gear - Right	9- 14
H545 1509	ADF Gear - Left	9- 12
H545 1518	Idle Gear - Separation	11- 12
H545 1522	Feed Roller Holder	9- 7
H545 1526	ADF Roller Cover	9- 17
H545 1528	Separation Spring	7- 16
H545 1532	Pressure Plate - Pick-up	7- 21
H545 1535	Upper Guide Stopper	7- 19
H545 1536	Spring Anchor	7- 17
H545 1537	Discharge Brush Holder	7- 7
H545 1538	Sheet - S2	7- 2
H545 1540	Reverse Pressure Plate	7- 29
H545 1550	Transfer Feed Belt	9- 10
H545 1555	Spring - Pressure Plate	7- 20
H545 1607	Drive Shaft	9- 13
H545 1610	Right Pick-up Roller	9- 11
H545 1611	Left Pick-up Roller	9- 9
H545 1617	Pick-up Sheet	7- 22
H545 1620	Pick-up Sheet 2	7- 23
H545 2100	Fusing Unit - 115V	15- 1
H545 2102	Fusing Unit - 230V (EUROPE)	15- 1
H545 2103	Fusing Unit - 230V (ASIA)	15- 1
H545 2109	Cleaning Pad	15- 19
H545 2110	Hot Roller	15- 24
H545 2111	Pressure Roller	15- 26
H545 2112	Upper Fusing Case	15- 6
H545 2113	Entrance Guide Plate	15- 20
H545 2117	Hot Roller Stripper	15- 16
H545 2118	Hot Roller Gear	15- 25
H545 2119	Roller Stopper	15- 21

Part No.	Description	Page and Index No.
H545 2122	Pressure Spring	15- 28
H545 2124	Exit Roller	17- 41
H545 2126	Lower Fusing Case	15- 29
H545 2128	Paper Exit Feeler	15- 32
H545 2129	Spring - Hot Roller Stripper	15- 15
H545 2130	Copy Tray	3- 24
H545 2131	Copy Tray Extention (US/AISA)	3- 25
H545 2132	Exit Roller Spring Plate	11- 19
H545 2133	Gear Paper Exit Roller - 21Z	19- 19
H545 2137	Right Terminal	15- 9
H545 2138	Left Terminal	15- 14
H545 2141	Left Plate - Fusing Lamp	15- 17
H545 2142	Plate - Fusing Lamp	15- 7
H545 2143	Upper Left Cover	15- 18
H545 2144	Upper Right Cover	15- 5
H545 2146	Spring - Fusing Exit	15- 31
H545 2147	Roller Grounding Plate	15- 33
H545 2148	Spring Plate - Cleaning	15- 3
H545 2149	Discharge Brush	9- 20
H545 2150	Fusing Drive Gear - 18z	19- 17
H545 2151	Gear - 46Z	19- 18
H545 2152	Grounding Plate - Fusing Unit	17- 10
H545 2153	Grounding Plate - Exit Roller	17- 14
H545 2154	Grounding Plate	11- 23
H545 2156	Fusing Bracket	15- 8
H545 2157	Decal - Warning (high Temperature)	15- 4
H545 2158	Spring Plate - Fusing Pressure	15- 30
H545 2169	Bushing - Pressure Roller	15- 27
H545 2401	Spring - Feed Roller - Left	17- 18
H545 2402	Spring - Feed Roller - Right	17- 19
H545 2403	Tension Roller Shaft	17- 29
H545 2404	Tension Roller	17- 20
H545 2405	Feed Roller	17- 34
H545 2406	Gear - Feed Roller - 43Z	19- 8
H545 2407	Feed Roller Color	19- 7

Part No.	Description	Page and Index No.
H545 2408	Feed Roller Color - Drive	19- 6
H545 2409	Coupled Gear 33/19z	19- 5
H545 2410	Release Spring	19- 12
H545 2411	Coupled Gear - 105/32z	19- 4
H545 2412	Coupled Gear - 41/23z	19- 11
H545 2413	Coupled Gear - 54/23z	19- 16
H545 2414	Coupled Gear - 41/40z	19- 14
H545 2415	Gear - 43Z	19- 15
H545 2416	Gear Link Arm	19- 13
H545 2417	Motor Cover	17- 25
H545 2418	Tonner End Sensor Holder	17- 22
H545 2419	Spring - Tonner End Sensor	17- 26
H545 2420	Grounding Terminal	17- 9
H545 2421	Development Terminal	17- 7
H545 2422	Terminal	17- 6
H545 2423	Charge Terminal	17- 12
H545 2424	Transfer Terminal	17- 8
H545 2425	Actuator - Registration Sensor	17- 37
H545 2426	Spring - Registration Sensor	17- 36
H545 2427	Spring Plate	19- 1
H545 2428	Shaft Spring	13- 8
H545 2429	Stepping Motor Dumper	19- 21
H545 2430	Lock Spring	17- 30
H545 2431	Discharge Brush - Transfer Roller	17- 16
H545 2432	Grounding Plate	17- 15
H545 2433	Ground Plate - Feed Roller -Plotter	25- 31
H545 2600	Laser Unit	13- 1
H545 2602	Optical Housing Cover	13- 4
H545 2604	Pressure Spring	13- 10
H545 2605	Shield Glass	13- 11
H545 2606	Shield Plate	13- 9
H545 2640	Shield - laser Diode	13- 5
H545 2641	Shield - Shield Glass	13- 13
H545 2642	Shield - Spring Plate	13- 12
H545 3100	Cassette Ass'y (US/ASIA)	27- 11

Part No.	Description	Page and Index No.
H545 3101	Cassette Slider (US/ASIA)	27- 12
H545 3102	Bottom Plate	27- 2
H545 3103	Cassette Cover (US/ASIA)	27- 1
H545 3104	Right Side Fence Ass'y (US/ASIA)	27- 10
H545 3105	Left Side Fence Ass'y (US/ASIA)	27- 5
H545 3106	End Fence	27- 15
H545 3107	Paper Size Selector (US/ASIA)	27- 14
H545 3109	Bottom Plate Lever	27- 9
H545 3110	Spring	27- 8
H545 3111	Bottom Plate Cap	27- 3
H545 3112	Paper Level Plate (US/ASIA)	27- 13
H545 3113	End Fence Spring	27- 16
H545 3114	Side Fence Sheet	27- 7
H545 3115	Bottom Plate Pad	27- 4
H545 3116	Lever Spring	27- 17
H545 3119	Actuator - Paper End	17- 31
H545 3122	Decal F4 (ASIA)	3- 33
H545 3123	Spring - Paper End Sensor	17- 32
H545 3125	Paper Feed Roller	25- 1
H545 3127	Shaft Stopper	25- 5
H545 3130	Idle Gear - 2nd - 24z	25- 29
H545 3132	Actuator - Paper Cassette	25- 10
H545 3141	Paper Transfer Roller	25- 3
H545 3143	Transfer Drive Roller	23- 11
H545 3144	Feed Roller Shaft	25- 4
H545 3148	Roller Shaft	23- 10
H545 3152	Upper Paper Guide	17- 21
H545 3155	Separation Pad:ass'y	23- 3
H545 3157	Separation Pad Cover	23- 5
H545 3160	Micro Switch Holder	25- 16
H545 3170	Gear 1 - 14Z	25- 28
H545 3171	Gear 2 - 31Z	25- 26
H545 3172	Gear 3 - 16Z	25- 27
H545 3173	Idler Gear 1 - 23z	25- 25
H545 3174	Idler Gear 2 - 14z	25- 24

Part No.	Description	Page and Index No.
H545 3175	Idler Gear 3 - 15z	25- 23
H545 3176	Idler Gear 4 - 14z	25- 14
H545 3177	Gear 4 - 14Z	25- 15
H545 3178	Spring - Gear	25- 30
H545 3179	Spacer	25- 32
H545 3180	Position Sensor Bracket	25- 6
H545 3189	Magnetic Clutch Bracket	25- 22
H545 3190	Right Guide Rail	23- 15
H545 3191	Left Guide Rail	23- 1
H545 3192	Cassette Film	27- 6
H545 3194	Pressure Plate - Right	23- 9
H545 3195	Pressure Plate - Left	23- 8
H545 3196	Sheet - PES	17- 33
H545 3199	Slow Down Gear - Lite	25- 33
H545 3200	Spring Plate	23- 2
H545 4101	Right Side Plate	19- 22
H545 4102	Left Bracket	17- 11
H545 4103	Scanner Release Lever	11- 11
H545 4104	Scanner Release Shaft	11- 6
H545 4105	NCU Stay	21- 11
H545 4106	Right Release Plate	11- 9
H545 4107	Left Release Plate	11- 4
H545 4108	Scanner Lock Spring	11- 10
H545 4109	Shielding Plate - FCU	21- 12
H545 4111	Shielding Sheet - NCU	21- 10
H545 4120	Fan Motor Duct	21- 5
H545 4121	Grounding Plate - PSU	25- 9
H545 4200	Lower Cover	23- 17
H545 4201	Lower Rear Cover	23- 7
H545 4205	Memory Card Cover	23- 22
H545 4206	PC Interface Cover	3- 20
H545 4211	Cover Shaft	23- 14
H545 4213	Decal - Parallel	23- 16
H545 4222	Lock Spring Plate	23- 6
H545 4222	Lock Spring Plate	23- 13

Part No.	Description	Page and Index No.
H545 4223	Film - Reverse	23- 12
H545 4224	Upper Rear Cover	3- 21
H545 4300	Upper Cover	3- 15
H545 4302	Right Original Guide	3- 13
H545 4303	Left Original Guide	3- 10
H545 4304	Scanner Stopper	11- 1
H545 4305	Spring Plate	11- 17
H545 4306	Spring Plate	11- 3
H545 4307	Rack - Original Guide	3- 22
H545 4308	Gear - Original Guide - 16Z	3- 23
H545 4311	Document Table - 1	3- 5
H545 4312	Document Table - 2	3- 17
H545 4313	Document Tray	3- 4
H545 4314	Document Table Extention (US/ASIA)	3- 16
H545 4315	Document Tray Extention (US/ASIA)	3- 3
H545 4320	RS232C Interface Cover	3- 18
H545 4327	Scanner Stopper Spring	11- 2
H545 4330	Fan Cover	3- 12
H545 4362	Decal - Cassette Cover	27- 18
H545 4400	Handset Bracket	3- 6
H545 4401	Handset Bracket Ass'y	3- 9
H545 4609	Operation Panel Ass'y - EU NRG	5- 1
H545 4651	Decal- LED Left	5- 6
H545 4652	Decal - LED Right	5- 9
H545 4653	Decal - Start/Stop	5- 10
H545 4654	Decal - Scale	5- 7
H545 4655	Quick Dial Sheet	5- 2
H545 4656	Quick Dial Cover	5- 5
H545 5000	PCB - PSU - 115V	21- 4
H545 5001	PCB - PSU - 230V	21- 4
H545 5010	Power Pack	21- 7
H545 5020	Power Supply Cord - 115V (US)	3- 1
H545 5022	Telephone Cable (FRANCE)	3- 2
H545 5054	Document Sensor - S1	7- 6
H545 5059	Fusing Lamp - 115V	15- 10

Part No.	Description	Page and Index No.
H545 5060	Lever Switch Ass'y	19- 3
H545 5061	Rear Cover Sensor Ass'y	25- 17
H545 5064	Speaker	23- 19
H545 5065	Fan Motor	21- 3
H545 5066	Main Motor - DC 20W	19- 10
H545 5067	Interlock SW - 5V	19- 2
H545 5068	Polygonal Mirror Motor - DC24V 0.3A	13- 14
H545 5074	Fusing Lamp - 230V	15- 10
H545 5076	Paper Transfer Sensor	25- 7
H545 5078	Toner End Sensor	17- 24
H545 5101	Resist Harness	17- 38
H545 5102	Harness - Toner End Sensor	17- 23
H545 5103	Harness - Cover Open Sensor	25- 18
H545 5104	NCU 1 Harness (US)	21- 8
H545 5105	Exit Sensor Harness	17- 40
H545 5106	Polygonal Motor Harness	13- 6
H545 5107	Lddr Harness	13- 7
H545 5109	CIS Harness	9- 2
H545 5110	Harness PP (US/ASIA)	21- 6
H545 5112	OPU-S1 Harness	7- 5
H545 5114	PSU Harness	21- 1
H545 5116	Main Harness - Multch Purpose	17- 28
H545 5119	Safety Switch Harness	21- 14
H545 5125	NCU 2 Harness (EUROPE/ASIA)	21- 8
H545 5126	Harness - NCU3 (EUROPE/ASIA)	21- 16
H545 5133	Paper Feed Sensor Harness	25- 11
H545 5134	Harness PP (EUROPE)	21- 6
H545 5135	Harness PSU-Heater	21- 2
H545 5136	Harness:OPU	5- 4
H545 5137	Main Harness - 2nd	23- 20
H545 5150	Grounding Wire - OPU	5- 3
H545 5151	Grounding Wire	25- 21
H545 5151	Grounding Wire	11- 21
H545 5152	Grounding Wire - Left Side	9- 4
H545 5152	Grounding Wire - Left Side	11- 24

Part No.	Description	Page and Index No.
H545 5173	Fusing Lamp Harness	15- 12
H545 5174	Jumper Harness (US/ASIA)	15- 13
H545 5930	PCB-NCU (US)	21- 9
H545 6080	PC I/F Board	3- 26
H545 7214	Operation Manual - Win Styler (US)	3- 29
H545 7216	Operation Manual - Win Styler (EUROPE)	3- 29
H551 7258	Ferrite Core (US/ASIA)	3- 34
H553 3861	Decal:super G3	9- 19

Part No.	Description	Page and Index No.
AA02 1030	Magnet Catch	17- 27

Part No.	Description	Page and Index No.
0805 3366	Bushing - 6mm	17-101
0805 3480	Bushing - 6mm	9-101
0805 3480	Bushing - 6mm	17-102
0805 3480	Bushing - 6mm	25-101
0807 2022	Washer - 3.3x10x0.5mm	25-103
1105 0229	Clamp	11-101
1105 0234	Clamp	21-101
1105 0234	Clamp	19-101
1105 0460	Clamp	19-102
1150 0024	Power Supply Cord - 230V (ASIA)	3- 1
1204 2355	Micro Switch - AM51632A531	21-102
1607 1046	Ferrite Core TC-15-10-12-FC	25-102

Part No.	Description	Page and Index No.
5214 1221	Rubber Foot	23- 18
5214 1221	Rubber Foot	23- 21
5447 2681	Snap Ring	7- 34
5447 2681	Snap Ring	17- 13
5488 6156	PCB - NCU - Fax S2	21- 9

